

Building a LOW-Band Receiving 4-Square Antenna Hi-Z Antennas

The Hi-Z Antennas 4-square receiving system utilizing shortened vertical elements has been designed to provide a relatively small footprint high-performance receiving antenna for the Amateur low bands covering 160 through 40 meters. The unique advantage of the 4-element system is that it can be switched electrically to provide receiving capability in four different directions. This system is also somewhat unique in that it uses high-impedance amplifiers at each antenna to extract the signals. Using these amplifiers negates the need for an extensive ground radial system around each antenna element in most areas with decent (1-2 foot deep dirt, not rock) ground conditions. This system can be used in place of the well-known Beverage receiving antennas that use very long wire elements and only provide one or two receiving directions per wire. This system can also be used in place of various types of receiving loops and arrays of multiple loops. This system when well built will outperform all but the largest of these other antenna types.

What can be achieved with the 4-Square

Most receiving systems being compared against another are most often compared for their front to back response ratio and their directivity. Front to back ratio is generally expressed in dB and then directivity, Relative Directivity Factor (RDF) in dB as well. There have been many spacing layout dimensions evaluated in order to get maximum performance from these arrays. The results of this evaluation has shown that for an emphasis on 160 meter band operation the side dimension of 80 to 100 feet will give great performance on 160 meters, good performance on 80 meters and OK performance on 40 meters. Reducing the side dimensions to between 50 and 70 feet will center the best performance on 80 meters and improve the 40-meter characteristics as well. Reducing the side dimensions to less than 50 feet reins in other problems requiring extreme accuracy in build dimensions and adjustments. It is not recommended for builders without access to accurate voltage and phase measuring equipment.

The following plots are based on a side dimension of 80 feet and show the resulting performance characteristics. The phasing delay values required in the 4-square controller have been chosen to use a middle of the road delay between best front to back/side-lobe ratio delay and best RDF needed delay.

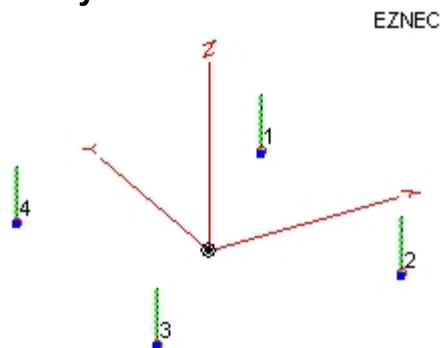

Basic 4 square element physical layout

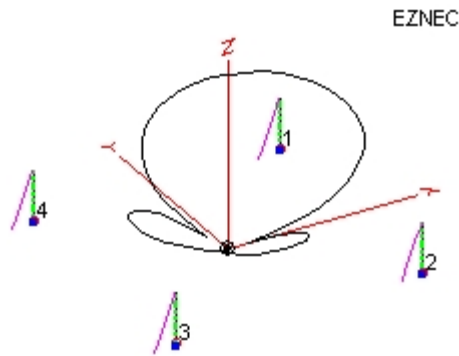

4 square physical layout with direction Switchable pattern overlay

As seen in the above layout the main lobe of the response is pointing in the direction of element 1. Electrically this pattern can be switched to point in the direction of any of the elements, 1 through 4. Ignore the slanted purple line from each element, as it is a representation of the level of current flowing in each element.

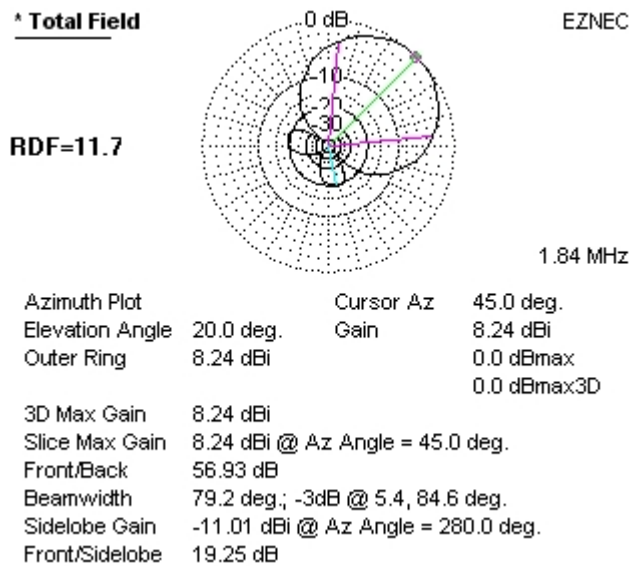

80-foot 4-square azimuth plot for 160 meters

The phasing values used for the 160-meter models of this antenna were Zero degrees for the front element, -218.5 degrees for the two center elements, and -77 degrees for the rear element. These values are based on a time delay phasing utilizing a fixed 180-degree inversion in the center elements. Time delay phasing allows wideband operation covering the 160,80, and 40-meter amateur bands. This is a simplified but accurate phasing model of the actual ideal combining circuitry.

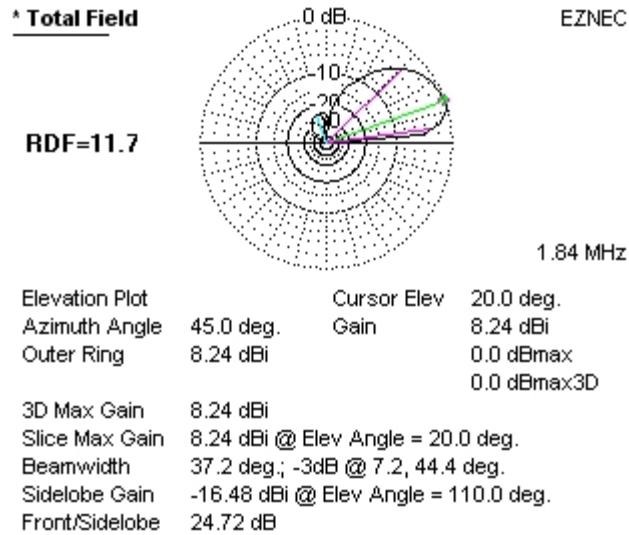

80-foot 4-square elevation plot for 160 meters

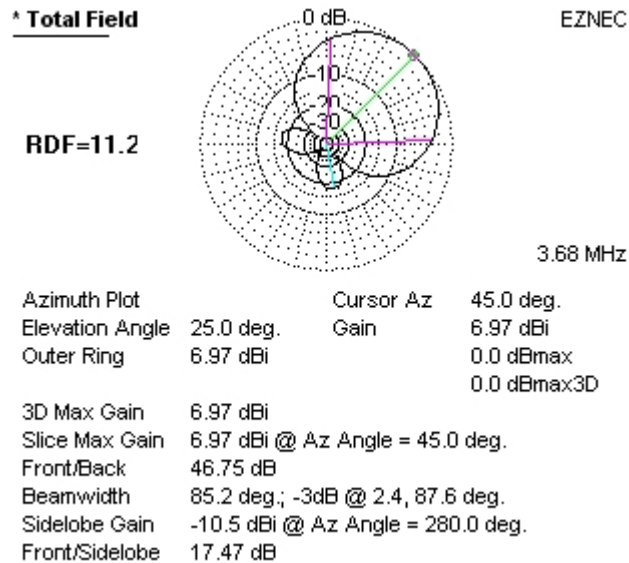

80-foot 4-square azimuth plot for 80 meters

Notice that there is very little performance change when doubling the operating frequency with the 80-foot side spacing. Below is a plot of an 850-foot long Beverage antenna for comparison. Notice, these antennas are being compared at the lower elevation angle of 20 degrees, which is not at the best RDF for the Beverage. Long haul DX is most often at very low angle.

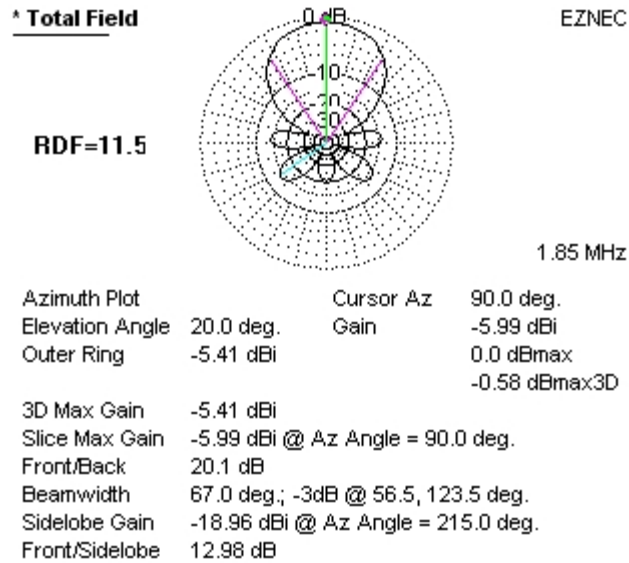

Comparison 850-foot long Beverage antenna azimuth plot

Constructing Elements for the array

There are likely as many ways to construct elements for a 4-square array, as there are people in the world. What the array needs is 4 insulated vertical elements that are as near identical as possible. Each vertical needs a companion ground rod. For array operation at 160 meters and below the elements should be 15 to 20 feet in length. The 20-foot length has been established to be optimum for best signal output level combined with voltage and phasing accuracy. The penalty in performance when dropping to 15-foot length is indeed real but difficult to measure and there are successful systems using this length. If one were not concerned with 160-meters but only higher bands such as twice the frequency at 80 meters then a 10-foot element would be fine. There is one 160-meter system operating with just 6-foot elements and lowest band performance is marginal at best. It also required measuring and adjusting element voltages and phases very accurately. If you want the best performance, stick with 15 to 20 foot length elements with 20-foot length being the best.

The diameter of the element has very little affect on the array. Some have used metal tubing while others have used fiberglass fishing rods with small wire strung through the hollow center. A mounting arrangement that utilizes large conducting surfaces close to the element will decrease the signal output of the element. Even wet wood posts should be kept a minimum of 4 inches away from the elements. Plastic or ceramic insulators are the best choice. PVC pipe works well. Each element will require a ground rod driven into at least 1 to 2 feet of soil. For areas of really bad and dry soil it is recommended to use two or even 3 short ground rods. Two feet length is fine.

Over rocky areas it is unclear how well the system will work due to some phase shifts in received signal with less than identical radial layouts. There are real and measurable inaccuracies when using radials below these Hi-Z elements. The best recommendation when radials are needed would be stringent accuracy in layout of 6 to 8 each 6-foot long radials below each element. Wire as small as 18 Ga. would be fine. Do not use radials unless absolutely necessary.

Element Examples



W7LR



W7IUUV



K1LT



W5XZ



KB7ZR



SM7BIC



K7TJR



K7TJR



K7TJR

Selecting an Array Layout

The antennas are arranged in a square configuration with side dimensions between 40 and 120 feet. Maximum signal reception is off the diagonal of any of the 4 corners. There are some performance considerations involved in the selection of the array dimensions.

At first glance one might think to make the array to the smallest dimensions. Unfortunately, the array becomes very sensitive to amplitude and phase errors at this smallest dimension. It is not recommended that one attempt the 40-foot spacing unless the antenna can be built on very flat and fertile ground. The ground conditions must be the same under each antenna. It would also be necessary to manufacture the elements and their connecting cables to exacting accuracy. These errors cause degraded performance on the 160-meter band. Even the 60-foot spacing is somewhat sensitive, however it is possible to get the array to work with reasonable care in element and cable construction. On side dimensions above 100 feet, the performance on 80 meters starts to suffer with side lobes reaching only -10dB . Therefore: if your interest extend down to 160 meters it is best to plan an array of side dimensions between 80 and 100 feet with a slight 160 meter RDF improvement on the 80 foot spacing.

The following picture is an Eznec viewing of the 4-square array. As can be seen the drawing is based on an X, Y, and Z coordinates. Eznec is an antenna analysis program by W7EL. For the following analysis we will use a dimension between each side antenna of 80 feet. Diagonally they will measure 1.414 times the side dimension.

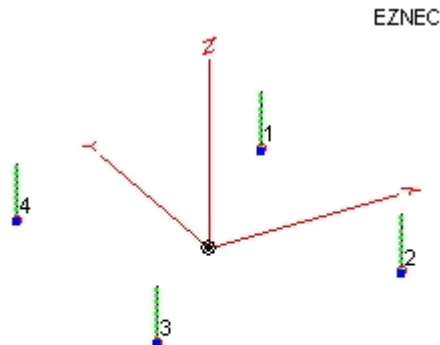

To calculate the needed connecting cables required for sending the signals from each antenna to the center controller one can use the following formula.

Formula: Side dimension X 0.707 plus 2 feet extra giving 56.6 feet plus 2 feet or 58.6 feet.

The length of these cables is not critical except that they all be the same length and from the same spool of cable. This ensures the phase delay for each cable will be equal and

therefore not require any length compensations. Actual length is unimportant due to the impedance matching used in the system.

There are two modes of operation for this array. There is the maximum RDF mode where the front to back ratio and the RDF are highest but there are side lobes around -15 dB down. The second mode is where all side lobes are minimized to -30dB and the RDF then slightly less. The second mode being particularly useful where there is high level unwanted signals coming from behind the array. These modes are changed by selection of the phase delay cables required for the array.

Maximum performance may be chosen as the best RDF or it may be chosen as the best overall front to back/side lobe ratio. This is a personal choice. You must choose which mode or where in between the two modes you will want to operate this array. Here are the plots as an aid in choosing which mode you want.

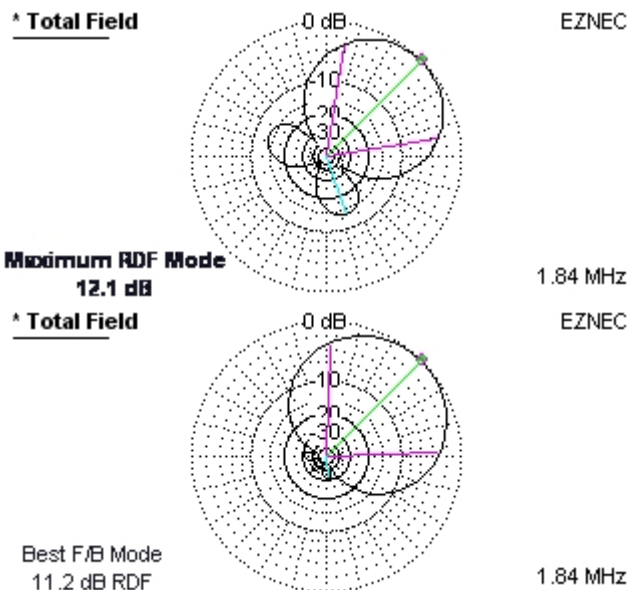

Another item to consider when selecting a mode for the array is the amount of overlap when switching directions with the array. The following plots show an increased loss in the side directions for the RDF optimized array versus the F/B optimized array.

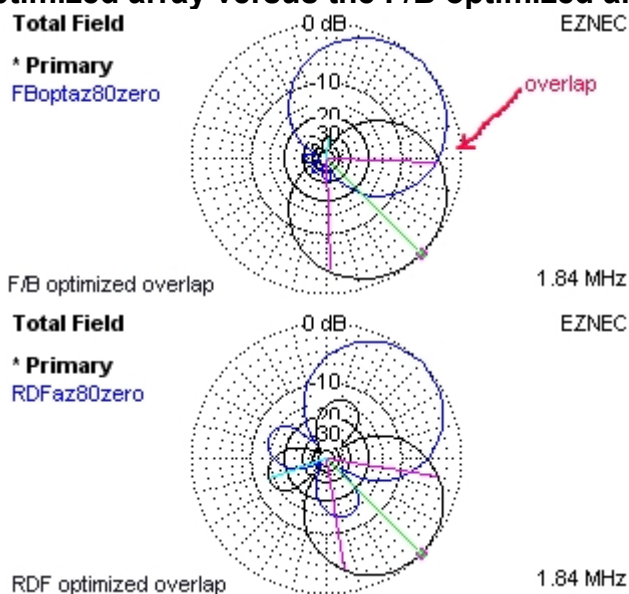

This increased loss would result in a lower RDF in the direction of the overlap. This would be of varying importance depending on the orientation of the array and the desired signal direction.

The following graph may also help in choosing which mode one may want to operate the array. This graph is intended to show the RDF trends for both 160 and 80-meter bands.

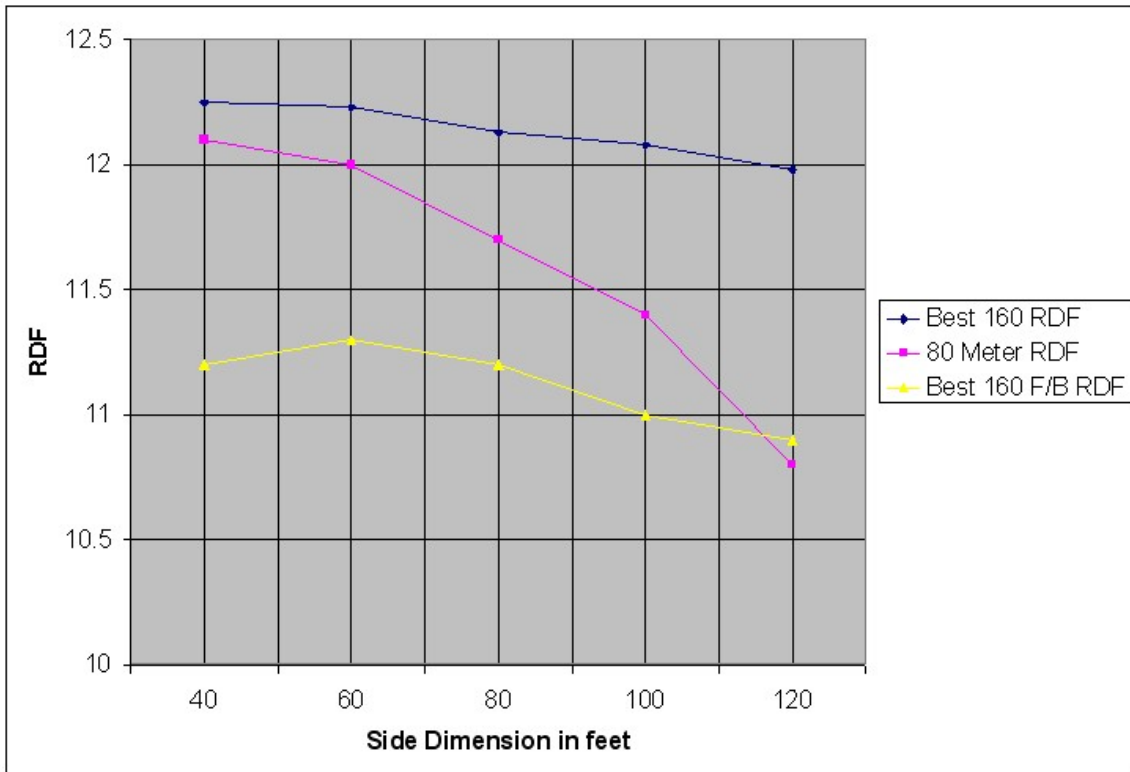

Unfortunately arrays with side dimensions of 40 to 60 feet are more sensitive to amplitude and phase errors on the 160-meter band. This makes 80 to 100 feet a best choice. From this plot one can also easily see that the RDF begins to fall off rapidly with wider spaced arrays on the 80-meter band. 80 meters band RDF was only graphed for the maximum RDF mode. Of course it is seriously degraded in the best F/B mode. However it would still be a useful 80-meter band array in this mode with an RDF near 10.5dB.

Choosing Delay Cable Values

The array dimensions and the values used for the delay cables attached to the controller box control the performance of this array. Once one has decided on a mode of operation and a side dimension for the array the delay cable values can be selected. The controller requires two delay cables, Delay2 and Delay1. The following chart can be used for selecting Delay2. Delay1 will be exactly $\frac{1}{2}$ that value. One can certainly choose any value in between the two stated modes as well. One can also choose to select phase delay values based on a NEC simulation of the array as well. For an NEC simulation of the array a value of -180 degrees must be added to the Delay1 value.

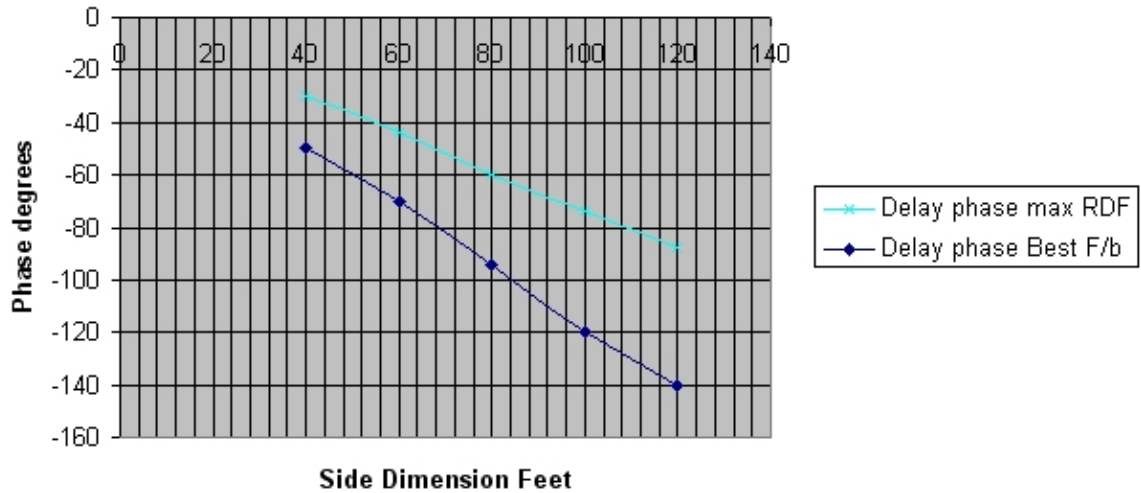

The operating frequency used for all the graphs and information preceding was 1.84Mhz. For an array with side dimension of 80 feet and a Max RDF mode a value of -60 degrees for Delay2 is indicated. This makes Delay1 value -30 degrees. Best F/B mode indicates -94 degrees for Delay2 and subsequent -47 for Delay1. As one can see there is an almost 30 degree spread between modes. This indicates the array is not overly sensitive to phase as long as the values are in the correct ratio of 0.5 to 1. This chart also shows how the array becomes more sensitive to phase difference for smaller side dimensions. The next step in the process of designing the array is to calculate the cable lengths for the delay cables chosen.

Important: For the most precise operation of an array using the Hi-Z Antennas 4-element controller one must make the following correction.

There is a finite time delay error between different phasing channels of the controller. This is mostly due to the 180-degree inversion transformers. This error can be easily corrected. At 1.840 MHz one can subtract 1 degree from the actual delay value of the Delay2 cable. You also subtract 3 degrees from the Delay 1 value. These numbers scale in frequency. That is, at twice the frequency, (3.680 MHz) the correction would double to 2 degrees for Delay 2 and 6 degrees for Delay 1.

If one had chosen a value from the charts above for a Delay2 value of 60 degrees, you would actually cut the cable for 59 degrees. Having chosen 60 degrees from the chart for Delay 2 would then require a 30-degree cable for Delay 1. Delay 1 then would be corrected to 27 degrees.

The operating frequency used for all the graphs and information preceding was 1.84Mhz. The free air wavelength for 1.84 MHz is 534.55 feet. One can use this value to calculate the phase delay cables. 534.55 feet is the value for 360 degrees or one complete wave cycle. To get a length for only 60 degrees, which we have chosen as a Delay2 value, one only needs to ratio the numbers. Formula: $60/360$ times 534.55. This equals 89.1 feet for a free air phase delay of -60 degrees. As we all should know, the velocity of wave propagation in coaxial cables is less than in air. This makes the delay in an equivalent length of coaxial cable greater for an equivalent air length. Knowing the velocity factor of your cable is important. For some RG-6 type Cable-TV cable the value is close to .86. One would simply take the 0.86 times the 89.1 feet previously calculated for a value of 76.6 feet. The Delay1 cable would then be 0.5 times that or 38.3 feet long.

Connecting the Elements

It is very important to connect the elements to the controller in the proper order.

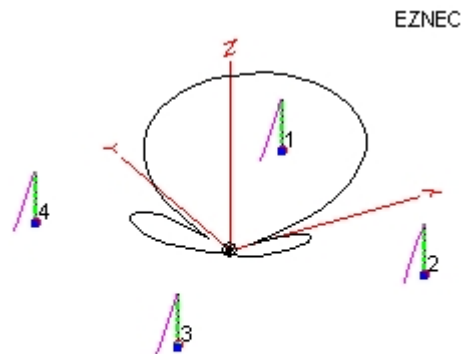

Looking at the layout above one can see that the pattern is pointed toward element 1. The pattern will be switched around the compass from element 1 to element 2 to element 3 and to element 4 as the control lines are activated. There are 2 control lines for switching directions. Having the pattern toward element 1 is the default position when no control lines are activated. You may point element 1 in any direction you like as long as the others then follow in sequence around the compass.

Switching directions

Switching directions of the pattern simply requires a contact closure to ground be applied to either or both of the control lines.

DIRECTION

- 1= Both control 1 and control 2 open
- 2= Ground control 1 and control 2 open
- 3= Ground control 2 and control 1 open
- 4= Ground control 1 and control2

Three different methods of directional control are shown in the following schematics.

Different Directional Control Methods.

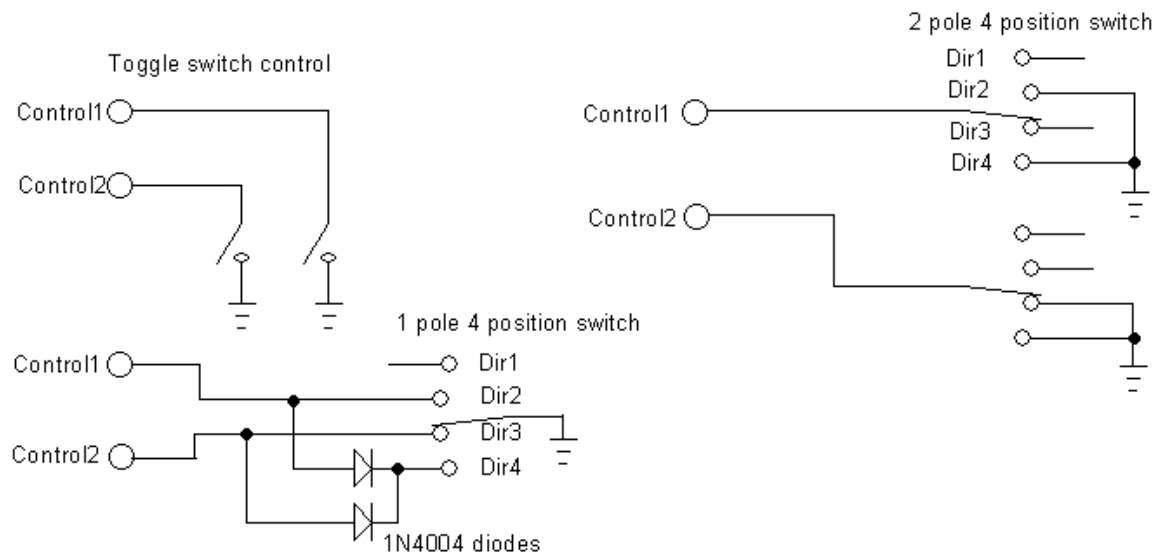

Controller

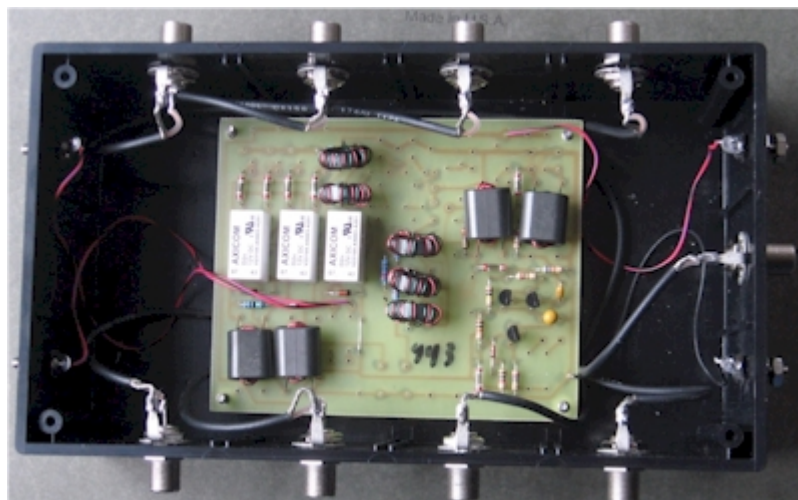

Separate Shack switch control

